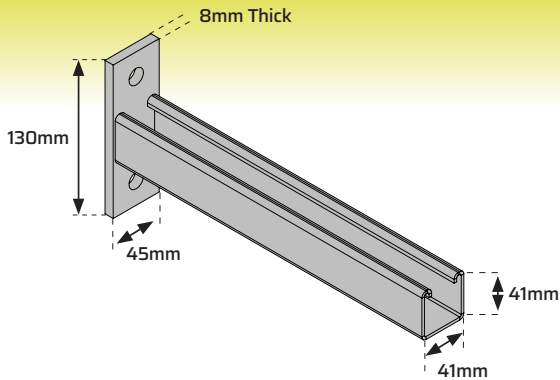

Cantilever Arms

Cantilever Arms Single

HOT-DIP GALVANISED (HDG)

CODE	LENGTH	MAX SAFE LOAD 1 (F KN)		
		LOAD 1	LOAD 2	LOAD 3
2013 01053	150	6.2	6.2	2.5
2013 01054	300	3.2	3.2	1.6
2013 01055	450	2.14	2.14	1.07
2013 01056	600	1.62	1.62	0.8
2013 01057	750	1.3	1.3	0.65
2013 01058	900	1	1	0.56
2013 15388	1000	0.72	0.72	0.35

Cantilever Arms Double

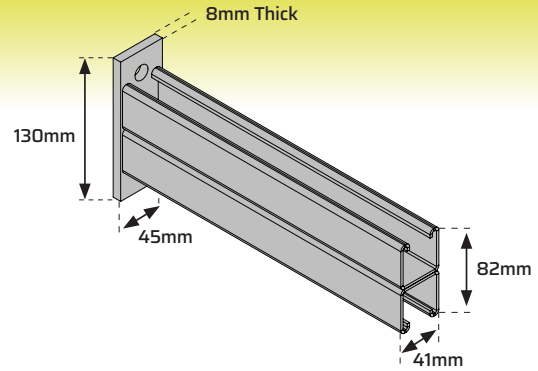
HOT-DIP GALVANISED (HDG)

CODE	LENGTH	MAX SAFE LOAD 1 (F KN)		
		LOAD 1	LOAD 2	LOAD 3
2013 01049	150	8.82	8.82	4.4
2013 01050	300	6.5	6.5	3.25
2013 01051	450	4.3	4.3	2.2
2013 01052	600	3.25	3.25	1.6

LOAD 1 Uniformly Distributed Load

LOAD 2 Centre Point Load

LOAD 3 End Point Load

TECHNICAL DATA

Steel Minimum Yield Stress:	275N/mm ²
Steel Thickness:	Back Plate 8mm & Channel 2.5mm
Clearance Hole:	Slotted pattern for easy alignment 14x25mm
	Minimum coating thickness
Hot-Dip Galvanised (HDG)	55µm

MAXIMUM SAFE LOADS
Loads apply to:

1. Arms fixed to a load bearing substrate with appropriate M12 Anchors

2. Arms bolted to:

- 2.5mm Thick Channel with:
- M12 Grade 8.8 set screws
- M10 DIN 125 washers
- 60Nm torque setting

Notes to Cantilever Arm Loads Data:

Published load data considers each of the following criteria:

- Maximum yield strength of the channel length section
- Deflection limit of the channel section = L/150
- Maximum yield strength of the back plate
- Safety factored failure load of the arm under test
- Maximum permitted deflection of the arm under test
- Factored slip load for arms bolted to channel