

- ✓ RIGHT PRODUCTS
- ✓ RIGHT PLACE
- ✓ RIGHT TIME

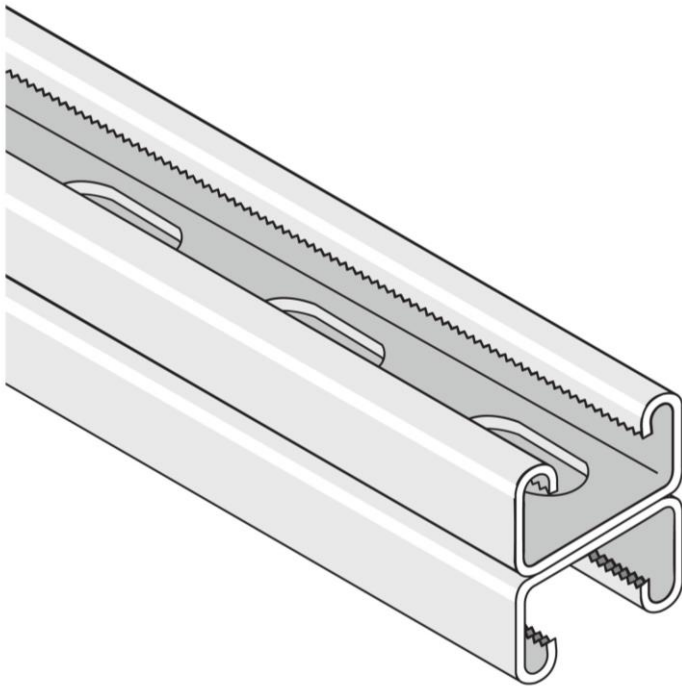

Slotted Channel, Back to Back, 41 x 21, 2.5mm

Slotted Channel, Back to Back, 41 x 21, 2.5mm finished in either Pre Galvanised (PG) or Hot Dipped Galvanised Steel (HDG). Available in 3m and 6m lengths.

Manufactured from mild steel (SG280D) to BS 6946.

These standard duty channel sections have been designed to provide a versatile and economical solution to industrial framing and support problems. The system comprises 2.5mm rolled galvanised steel channel sections which may be easily assembled / modified using brackets, spring nuts and bolts.

Technical data supplied by the manufacturer.

Description

Dimensions: Back to Back, 41 x 21, 2.5mm

Lengths: 3m and 6m

Material: Mild Steel

Finish: Pre Galvanised (PG) or Hot Dipped Galvanised Steel (HDG)

- Channel manufactured to comply with BS 6946 from Mild Steel (SG280D) with a minimum yield stress of 280N/mm²
- Hot Dipped Galvanised (HDG) 55 Micron finish to BS EN ISO 1461
- Pre Galvanised (PG) BS EN 10346 Zinc coating Z275

Remark: This technical data sheet replaces all previous versions. The technical data contained herein is given in good faith and we cannot be held liable for any errors, inaccuracies, omissions or editorial failings. The information detailed in this technical data sheet is given by way of indication and is not exhaustive, users should contact either the seller or the manufacturer of the product for additional technical information concerning its use, if they think the information in their possession needs to be clarified in any way. Any illustrations shown are indicative only, and dimensions may differ slightly from batch to batch.