

- ✓ RIGHT PRODUCTS
- ✓ RIGHT PLACE
- ✓ RIGHT TIME



Armorgard DuctRack™ DR1

The Armorgard DuctRack range promotes safe and efficient storage and transportation. All while protecting the ducting and pipework on site.

With two different sizes certified to carry a total load capacity of 1 tonne in weight.

Featuring centrally fixed wheels that enable it to turn within its own footprint, and handles on each corner, whether you are operating with colleagues or on your own, the DuctRack makes lightwork of moving large loads around site.



Technical data supplied by the manufacturer

Additional Information

- Features the SafeStop dead-man braking system for ultimate user safety.
- Unit can be folded down and stacked when not in use.
- Specialised wheel layout ensures good stability and a compact turning circle.
- Optional shelf and side kits improve storage capacity.
- Includes 6" Heavy Duty Castors as Standard

MEP & HVAC FIXING SPECIALISTS

Springhead Enterprise Park, Springhead Road, Northfleet, Kent DA11 8HJ
 T 01322 274226 F 01322 278178 E sales@fixmart.co.uk www.fixmart.co.uk

- ✓ RIGHT PRODUCTS
- ✓ RIGHT PLACE
- ✓ RIGHT TIME

Product	Armorgard DuctRack™ DR1
External dimensions (HxWxD)	1820 x 1830 x 760mm
Weight	138kg
Colour	Black Grey: RAL 7021
Finished coating	Powder Coated Steel
Material	Steel
Material thickness	2.5mm & 3mm
Does it have forklift skids?	Yes
Does it have gas arms?	No
Optional extras available	Shelf, Side Kit
Are castors standard or optional extra?	Standard
How are the castors fitted?	Castor Plates

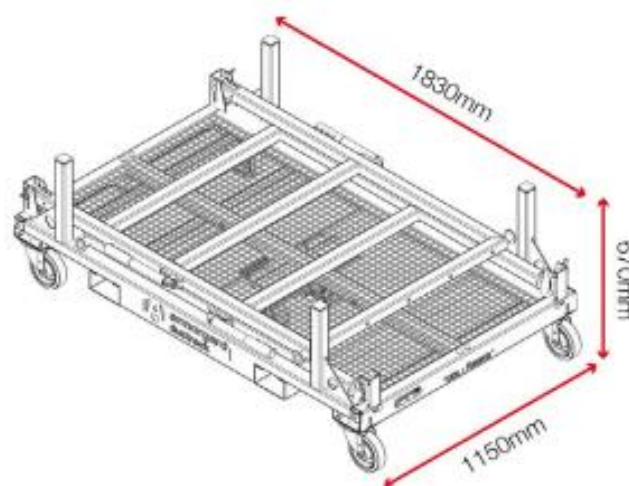
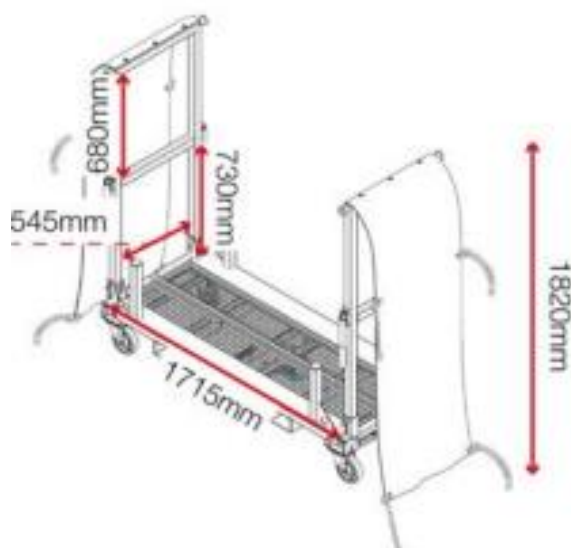

Remark: This technical data sheet replaces all previous versions. The technical data contained herein is given in good faith and we cannot be held liable for any errors, inaccuracies, omissions or editorial failings. The information detailed in this technical data sheet is given by way of indication and is not exhaustive, users should contact either the seller or the manufacturer of the product for additional technical information concerning its use, if they think the information in their possession needs to be clarified in any way.

- ✓ RIGHT PRODUCTS
- ✓ RIGHT PLACE
- ✓ RIGHT TIME



Armorgard DuctRack™ DR2

The Armorgard DuctRack range promotes safe and efficient storage and transportation. All while protecting the ducting and pipework on site.

With two different sizes certified to carry a total load capacity of 1 tonne in weight.

Featuring centrally fixed wheels that enable it to turn within its own footprint, and handles on each corner, whether you are operating with colleagues or on your own, the DuctRack makes lightwork of moving large loads around site.



Technical data supplied by the manufacturer

Additional Information

- Features the SafeStop dead-man braking system for ultimate user safety.
- Unit can be folded down and stacked when not in use.
- Specialised wheel layout ensures good stability and a compact turning circle.
- Optional shelf and side kits improve storage capacity.
- Includes 6" Heavy Duty Castors as Standard

MEP & HVAC FIXING SPECIALISTS

Springhead Enterprise Park, Springhead Road, Northfleet, Kent DA11 8HJ
 T 01322 274226 F 01322 278178 E sales@fixmart.co.uk www.fixmart.co.uk

- ✓ RIGHT PRODUCTS
- ✓ RIGHT PLACE
- ✓ RIGHT TIME

Product	Armorgard DuctRack™ DR2
External dimensions (HxWxD)	1820 x 1830 x 1150mm
Weight	158kg
Colour	Black Grey: RAL 7021
Finished coating	Powder Coated Steel
Material	Steel
Material thickness	2.5mm & 3mm
Does it have forklift skids?	Yes
Does it have gas arms?	No
Optional extras available	Shelf, side kit
Are castors standard or optional extra?	Standard
How are the castors fitted?	Caster Plates

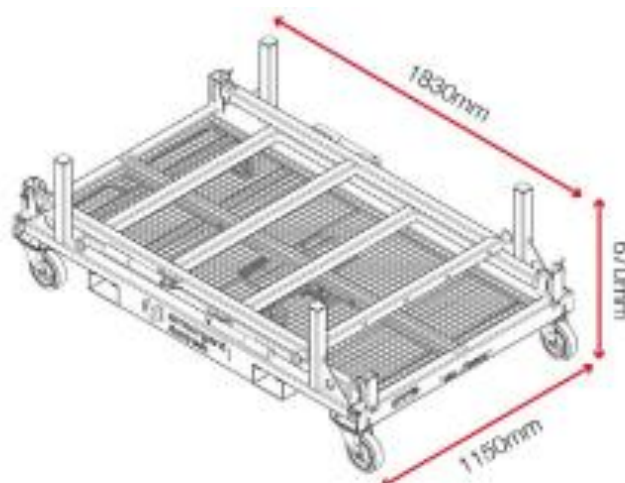
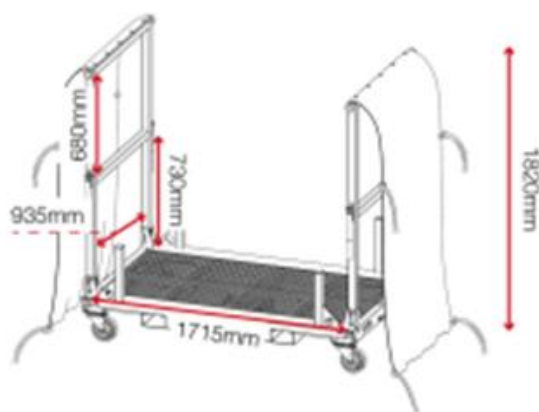

Remark: This technical data sheet replaces all previous versions. The technical data contained herein is given in good faith and we cannot be held liable for any errors, inaccuracies, omissions or editorial failings. The information detailed in this technical data sheet is given by way of indication and is not exhaustive, users should contact either the seller or the manufacturer of the product for additional technical information concerning its use, if they think the information in their possession needs to be clarified in any way.