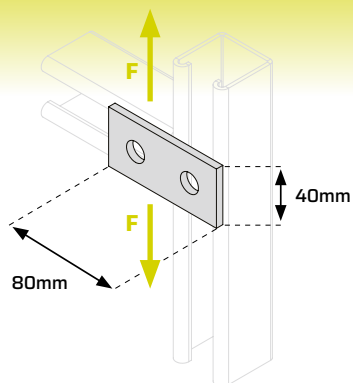
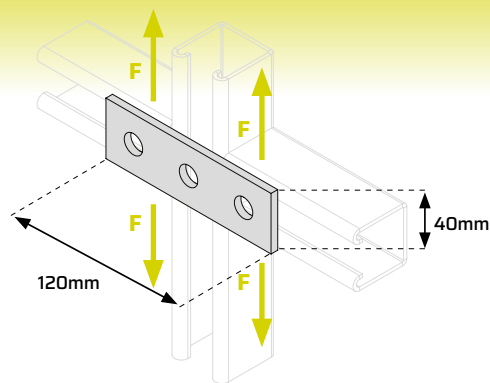

# Splice Plates

**Splice Plate 2-Hole**

**HOT-DIP GALVANISED (HDG)**

CODE	SIZE	MAX SAFE LOAD F kN
2013 01072	40 x 80mm	2.35

**Splice Plate 3-Hole**

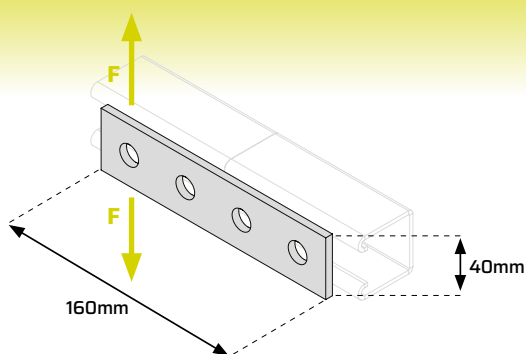
**HOT-DIP GALVANISED (HDG)**

CODE	SIZE	MAX SAFE LOAD F kN
2013 01073	40 x 120mm	3.785

**Splice Plate 4-Hole**

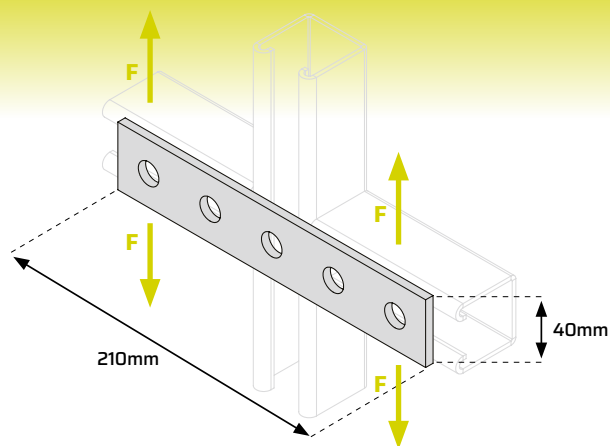
**HOT-DIP GALVANISED (HDG)**

CODE	SIZE	MAX SAFE LOAD F kN
2013 01074	40 x 160mm	2.307

**Splice Plate 5-Hole**

**HOT-DIP GALVANISED (HDG)**

CODE	SIZE	MAX SAFE LOAD F kN
2013 01075	40 x 210mm	2.307

**TECHNICAL DATA**

Steel Minimum Yield Stress:	275N/mm <sup>2</sup>
Steel Thickness:	5mm
Clearance Hole:	14mm
	<b>Minimum coating thickness</b>
Hot-Dip Galvanised (HDG)	55µm