

# 41 x 41 x 2.5 - Slotted Channel

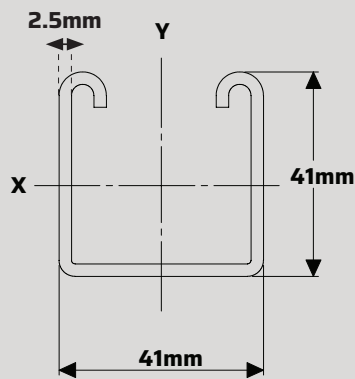

SECTION A-A

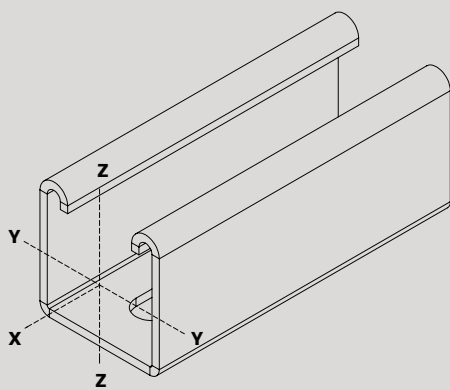
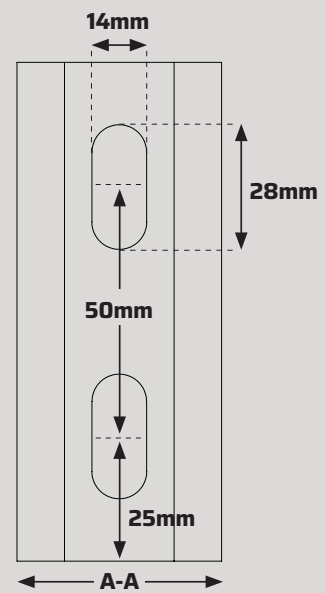

**TECHNICAL DATA**

Product Weight:	2.52 kg/m
Minimum Yield Stress:	280N/mm <sup>2</sup>
Uniformly distributed load for 1M (Fmax):	415 kg/m

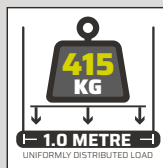

Area	MOMENT OF INERTIA		SECTION MODULUS		RADIUS OF GYRATION	
	I y-y	I z-z	S y-y	S z-z	R y-y	R z-z
3.06 cm <sup>2</sup>	6.24cm <sup>4</sup>	9.08cm <sup>4</sup>	2.59cm <sup>3</sup>	4.43cm <sup>3</sup>	1.43cm	1.72cm

**FINISH DATA**

**PRE-GALVANISED CHANNELS (PG)**

Material Standard:	BS EN 10346 / BS 6946
Material Specification:	S280GD + Z275
Minimum Yield Stress:	280N/mm <sup>2</sup>
PG Minimum Zinc Coating Mass:	275g/m <sup>2</sup>
PG Typical Zinc Coating Thickness:	20µm

**HOT-DIP GALVANISED CHANNELS (HDG)**

Material Standard:	BS EN 10346 / BS 6946
Material Specification:	S280GD + BS EN 1461
Minimum Yield Strength:	280N/mm <sup>2</sup>
Hot Dip Galvanising to:	BS EN 1461:2009
Minimum Average Coating Thickness:	55µm

# 41 x 41 x 2.5 - Slotted Channel

## LOAD DATA

CODE	FINISH HDG / PG	LENGTH (L) mm	ULTIMATE LOADS - LOAD 1		DESIGN LOADS			
			ULTIMATE UNIFORMLY DISTRIBUTED LOAD	MAX DEFLECTION	LOAD 1 - SAFE UNIFORMLY DISTRIBUTED LOAD	LOAD 2 - SAFE CENTRAL POINT LOAD	LOAD 3 - SAFE TWO POINT LOAD	LOAD 4 - SAFE THREE POINT LOAD
			Fmax kN	<i>f</i> <sub>max</sub> mm	F kN	F kN	F kN	F kN
<b>HOT-DIP GALVANISED</b>								
2011 11254	HDG	3000	1.355	34.37	0.797	0.380	0.305	0.160
2011 11255	HDG	6000	0.679	142.5	0.399	0.190	0.153	0.080
<b>PRE-GALVANISED</b>								
2011 01009	PG	3000	1.355	34.37	0.797	0.380	0.305	0.160
2011 01010	PG	6000	0.679	142.5	0.399	0.190	0.153	0.080
<b>PRE-CUT LENGTHS</b>								
2015 01160	PG	250	16.093	0.32	9.466	9.029	7.267	3.815
2015 01165	PG	500	8.146	0.8	4.792	2.285	1.839	0.965
2015 01170	PG	750	5.430	1.82	3.194	1.523	1.226	0.644
2015 01147	PG	1000	4.068	3.38	2.393	1.484	1.194	0.627
2015 01149	PG	1200	3.362	4.97	1.978	0.943	0.758	0.398
2015 01152	PG	1500	2.676	7.81	1.574	0.751	0.604	0.317
2015 01155	PG	1700	2.378	10.45	1.399	0.667	0.604	0.281
2015 01158	PG	2000	2.075	15.1	1.221	0.582	0.468	0.246

**LOAD 1** Safe Uniformly Distributed Load

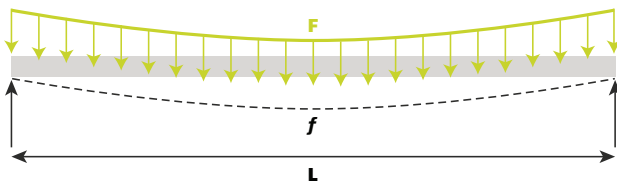

**LOAD 3** Safe Two Point Load

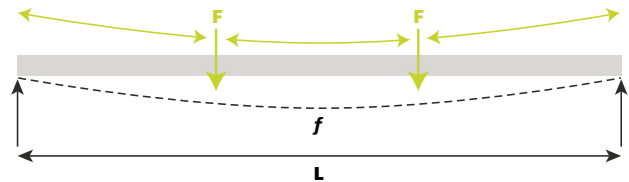

**LOAD 2** Safe Central Point Load

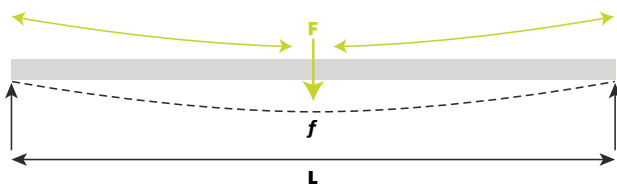

**LOAD 4** Safe Three Point Load

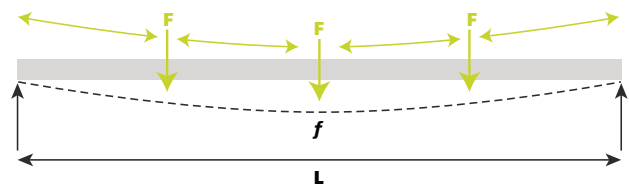

**Notes to Beam Loads data:**

- Yield Stress = 280N/mm<sup>2</sup>
- Modulus of elasticity: E = 210kN/mm<sup>2</sup>
- All beam loads are for simply supported beams
- All load data is for applied loads. The channel self-weight is already deducted.
- Ultimate Loads - maximum uniformly distributed load limited by stress using safety coefficient = 1.7
- Design Loads - maximum loads limited by deflection:  $f = L/200$ . (Values in italics are limited by stress not deflection)

# Cantilver & Column Load Data - 41 x 41 x 2.5 Slotted Channel

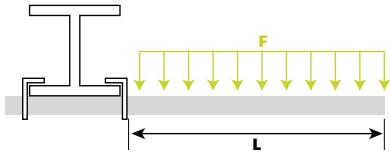
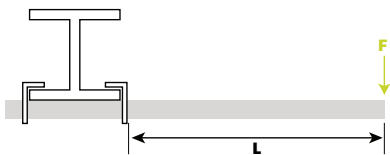
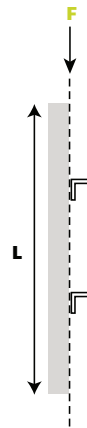
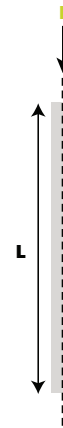
**CANTILEVER LOADS**
**LOAD 1** Uniformly Distributed Load

**LOAD 2** End Point Load

**COLUMN LOADS**
**LOAD 1** Eccentrically Loaded

**LOAD 2** Centrally Loaded

**CANTILEVER - DESIGN LOADS**
**COLUMN DESIGN LOADS**

LENGTH (OVER HANG TO SUSPEND FROM)*	LOAD 1 - UNIFORMLY DISTRIBUTED LOAD	LOAD 2 - END POINT LOAD	LOAD 1 - ECCENTRICALLY LOADED	LOAD 2 - CONCENTRICALLY LOADED
L (mm)	F kN	F kN	F kN	F kN
500mm	2.23	1.06	8.32	33.00
1000mm	1.06	0.52	6.67	30.29

\*Length of the overhang to suspend from rather than total length

**Notes to Column & Cantilever Loads data:**

- Yield Stress = 275N/mm<sup>2</sup>
- Modulus of elasticity: E = 210kN/mm<sup>2</sup>

**Cantilver:**

- All load data is for applied loads. The channel self-weight is already deducted.
- Design Loads - maximum loads limited by deflection:  $f = L/150$ .  
(Values in italics are limited by stress using safety coefficient =1.7)
- Load capacity of beam clamps and primary steel must be considered

**Column:**

- Design loads include safety coefficient = 1.7
- Loads are calculated for pin-pin connections and column effective length of 1.0
- Centric loads - loads applied at the centroid of the column (typical for beams placed on top of columns)
- Eccentric Loads - for loads applied at the open face of the channel (typical of channel bracket connections)